

PROGEF Standard
Redukční ventil typ 582
Šroubení s nátrubky pro polyfúzi metric
Bez manometru

Provedení:

- Membrána PTFE/EPDM
- Integrované montážní závity v tělese ventilu
- 0.5 - 9.0 bar

0.3 - 3.0 bar na zakázku

Manometr na zakázku

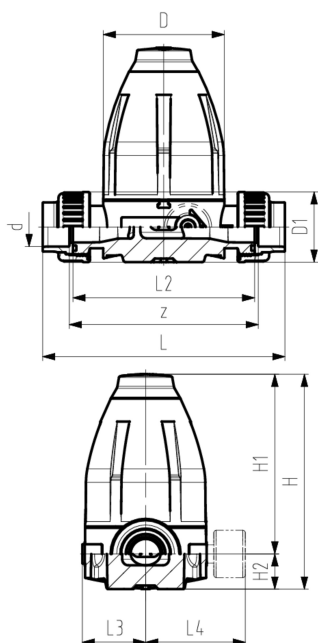

d (mm)	DN (mm)	PN (bar)	O-kroužek EPDM kód	O-kroužek FKM kód	Váha (kg)	SP	GP
20	15	10	167 582 102	167 582 112	0.600	1	0
25	20	10	167 582 103	167 582 113	1.300	1	0
32	25	10	167 582 104	167 582 114	1.320	1	0
40	32	10	167 582 105	167 582 115	3.530	1	0
50	40	10	167 582 106	167 582 116	3.650	1	0
63	50	10	167 582 107	167 582 117	3.800	1	0

d (mm)	D (mm)	D1 (mm)	H (mm)	H1 (mm)	H2 (mm)	H3 (mm)	L (mm)	L2 (mm)	L3 (mm)	L5 (mm)	M	z (mm)	Nejbl. inch (inch)
20	79	48	132	111	21	12	158	120	42	40	M6	126	½
25	100	58	177	148	29	14	192	150	53	46	M6	156	¾
32	100	65	177	148	29	14	196	150	53	46	M6	156	1
40	147	77	251	207	44	21	255	205	76	65	M8	211	1 ¼
50	147	84	251	207	44	21	261	205	76	65	M8	211	1 ½
63	147	111	251	207	44	21	269	205	76	65	M8	211	2

Technické údaje o produktech nejsou závazné. Konstrukční a rozměrové změny vyhrazeny.

Přeloženo z originálu výrobce

PPS Engineering CZ, s.r.o., zastoupení Georg Fischer Piping Systems

info@ppsengineering.cz

www.ppsengineering.cz

© PPS 10/2018